

Fire Safe Valves

Type 01643 - Actuated Globe Valve



Cryogenic-Globe Valves with Pneumatic Actuator, PN50 (DN150=PN40)

"Fire safe" type test approval acc. to EN ISO 10497

Stainless steel body and topwork

Actuator - air opens, spring closes or contrary

"live loaded" gland packing

"cleaned and degreased for oxygen service" - the standard actuator is not cleaned and degreased for oxygen

Part No. 01643.X.0010

possible connections:

- Butt weld connection for stainless steel pipes acc. to ISO 1127 or ASTM A312
- Socket weld connection for stainless steel pipes acc. to ISO 1127 or ASTM A312
- Female thread connection (G) acc. to ISO 228/1 or NPT acc. to ANSI B 1.20.1

Please specify the required connection when ordering!

Available options - on request only:

- Solenoid valves · Electropneumatic positioner · Inductive Proximity Switches
- Position and Limit Switches · Air control sets · Electric actuator
- Welded stainless steel stubs acc. to ISO 1127 or ASTM A312 - length FF + 200mm
- Actuator "cleaned and degreased for oxygen service" · Further pipe wall thicknesses
- Valve with check disc · valve with control disc (tapered design)

Applications:

Approved for air gases, vapours and cryogenic liquefied gases incl. LNG.

Working temperature: -196°C / -321°F (77K) up to +120°C / +248°F (393K)



Materials	DIN EN	ASTM
1 Body	1.4308	A 351 CF8
2 Valve seal	PTFE / Carbon filled (25%)	
3 Disc	1.4301	A 276 Grade 304
4 Bonnet Gasket	Graphite	
5 Headpiece	1.4301	A 276 Grade 304
6 Bolts	1.4301/A2	A 194 B8
7 Elongation tube	1.4541	A 213 TP 321
8 Stem	1.4301	A 276 Grade 304
9 Gland packing	Graphite / PTFE / MICA	
10 Gland nut	1.4305	A 276 Grade 303
11 Pillars	1.4404	A 276 Grade 316L
12 Bush	CW452K	B 159 UNS C51900

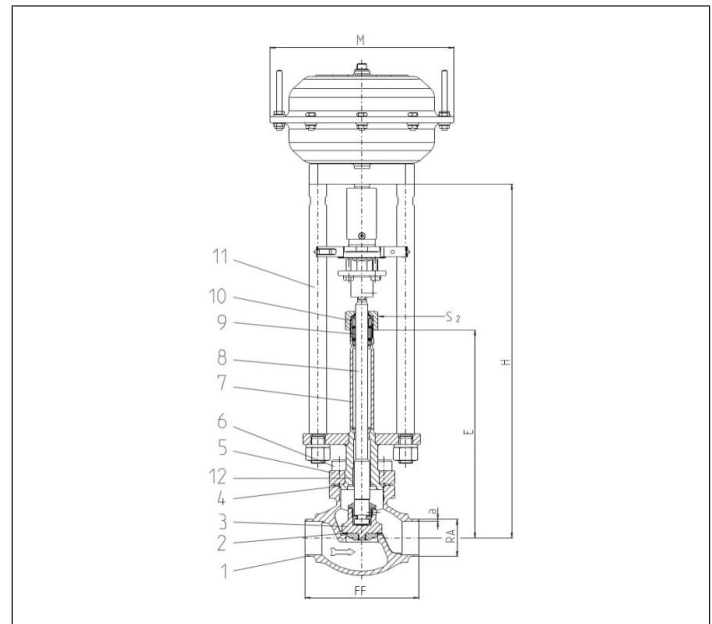

Type 01643 - Standard design	Technical Data											
Nominal size	DN	10	15	20	25	32	40	50	65	80	100	150
Dimension code	.X.	0100	0150	0200	0250	0320	0400	0500	0650	0800	1000	1500
Face-to-face dimension	FF	70	85	100	115	115	130	155	205	245	280	400
Height	H	370	370	370	375	405	420	425	510	575	635	685
Length	E	195	195	200	200	230	230	235	300	300	300	350
Actuator-Ø	M	dependent on actuator										
Wrench size across flats	S ₂	30	30	30	30	36	36	36	36	36	41	41
Weight w/o actuator	ca. kg	1.9	2.15	2.4	3.1	3.8	6.5	9.0	15.2	20.0	28.0	60.9
Stroke	mm	10	10	7	9	9	11	15	23	23	30	40

Dimensions in mm. Compliance of tightness requirements acc. to EN 1626 for DN150 up to 20 bar differential pressure. In the range of >20-40 bar, 350-700ml per second (1 bar, 20°C [68°F]) are reached. * These figures refer to measurements for the flow direction.

Fire Safe Valves

Type 01643 - Actuated Globe Valve



Connection types

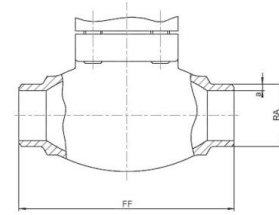

Butt weld connection acc. to · ISO 1127

DN	Face-to-face dim. (FF) [mm]	Outside pipe-Ø ISO (RA) [mm]	Wall thickness pipe ISO (a) [mm]	*Kvs-value [m³/h]	*Cv-value [gal/min]	**Weight w.a. [kg]	Order reference
10	70	13.5	1.0	1.6	1.9	1.9	BW 13.5x1.0
15	85	17.2	1.6	3.8	4.4	2.2	BW 17.2x1.6
15	85	21.3	2.0	4.3	5.0	2.2	BW 21.3x2.0
20	100	26.9	2.0	6.7	7.8	2.4	BW 26.9x2.0
25	115	33.7	2.0	11.5	13.4	3.1	BW 33.7x2.0
32	115	38.0	2.0	14.0	16.2	3.8	BW 38.0x2.0
40	130	42.4	2.0	20.6	23.9	6.5	BW 42.4x2.0
40	130	48.3	2.0	22.6	26.3	6.5	BW 48.3x2.0
50	155	60.3	2.0	37.1	43.2	9.0	BW 60.3x2.0
65	205	76.1	2.6	71.1	82.9	15.2	BW 76.1x2.6
80	245	88.9	3.2	104.0	121.3	20.0	BW 88.9x3.2
100	280	114.3	6.0	170.0	198.3	28.0	BW 114.3x6.0
150	400	168.3	7.1	350.0	408.4	60.9	BW 168.3x7.1

Butt weld connection acc. to · ASTM A312

DN	Face-to-face dim. (FF) [mm]	Outside pipe-Ø ASTM (RA) [inch / mm]	Wall thickness pipe ASTM (a) [mm]	*Kvs-value [m³/h]	*Cv-value [gal/min]	**Weight w.a. [kg]	Order reference
10	70	1/4" / 13.72	1.65	1.6	1.9	1.9	BW 13.72x1.65
15	85	1/2" / 17.15	1.65	3.8	4.4	2.2	BW 17.15x1.65
15	85	1/2" / 21.34	2.11	4.3	5.0	2.2	BW 21.34x2.11
20	100	3/4" / 26.67	2.11	6.7	7.8	2.4	BW 26.67x2.11
25	115	1" / 33.40	2.77	11.5	13.4	3.1	BW 33.40x2.77
40	130	1-1/2" / 42.16	2.77	20.6	23.9	6.5	BW 42.16x2.77
40	130	1-1/2" / 48.26	2.77	22.6	26.3	6.5	BW 48.26x2.77
50	155	2" / 60.32	2.77	37.1	43.2	9.0	BW 60.32x2.77
65	205	2-1/2" / 73.02	3.05	71.1	82.9	15.2	BW 73.02x3.05
80	245	3" / 88.90	3.05	104.0	121.3	20.0	BW 88.90x3.05
100	280	4" / 114.30	3.05	170.0	198.3	28.0	BW 114.30x3.05
150	400	6" / 168.27	3.40	350.0	408.4	60.9	BW 168.27x3.40
10	70	1/4" / 13.72	2.24	1.6	1.9	1.9	BW 13.72x2.24
15	85	1/2" / 17.15	2.31	3.8	4.4	2.2	BW 17.15x2.31
15	85	1/2" / 21.34	2.77	4.3	5.0	2.2	BW 21.34x2.77
20	100	3/4" / 26.67	2.87	6.7	7.8	2.4	BW 26.67x2.87
25	115	1" / 33.40	3.38	11.5	13.4	3.1	BW 33.40x3.38
40	130	1-1/2" / 42.16	3.56	20.6	23.9	6.5	BW 42.16x3.56
40	130	1-1/2" / 48.26	3.68	22.6	26.3	6.5	BW 48.26x3.68
50	155	2" / 60.32	3.91	37.1	43.2	9.0	BW 60.32x3.91
65	205	2-1/2" / 73.02	5.16	71.1	82.9	15.2	BW 73.02x5.16
80	245	3" / 88.90	5.49	104.0	121.3	20.0	BW 88.90x5.49
100	280	4" / 114.30	6.02	170.0	198.3	28.0	BW 114.30x6.02
150	400	6" / 168.27	7.11	350.0	408.4	60.9	BW 168.27x7.11

* These figures refer to measurements for the flow direction.

** w.a. = without actuator

Fire Safe Valves

Type 01643 - Actuated Globe Valve



Connection types

Socket weld connection acc. to

- ISO 1127
- ASTM A312

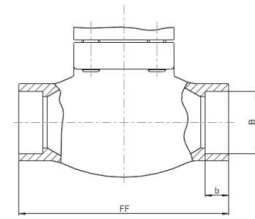

DN	Face-to-face dim. (FF) [mm]	Socket depth (b) [mm]	Socket diameter (B) [mm]	*Kvs-value [m ³ /h]	*Cv-value [gal/min]	**Weight, w.a. [kg]	order reference [ØISO / ØASTM]
10	70	6	14.1	1.6	1.9	1.9	SW 13.5 / 13.72
15	85	10	17.5	3.8	4.4	2.2	SW 17.2 / 17.15
15	85	10	21.5	4.3	5.0	2.2	SW 21.3 / 21.34
20	100	13	27.5	6.7	7.8	2.4	SW 26.9 / 26.67
25	115	13	34.1	11.5	13.4	3.1	SW 33.7 / 33.4
40	130	13	42.8	20.6	23.9	6.5	SW 42.4 / 42.16
40	130	13	48.6	22.6	26.3	6.5	SW 48.3 / 48.26
50	155	16	61.1	37.1	43.2	9.0	SW 60.3 / 60.32
65	205	16	74.0	71.1	82.9	15.1	SW 73.02
65	205	16	76.8	71.1	82.9	15.2	SW 76.1
80	245	16	90.0	104.0	121.3	20.0	SW 88.9
100	280	20	114.8	170.0	198.3	28.0	SW 114.3
150	400	20	168.2	350.0	408.4	60.9	SW 168.3 / 168.27

Female thread connection acc. to

- ISO 228/1 (G)
- NPT acc. to ANSI B 1.20.1 (NPT)

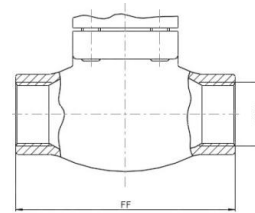

DN	Face-to-face dim. (FF) [mm]	Thread size (GW)	*Kvs-value [m ³ /h]	*Cv-value [gal/min]	**Weight, w.a. [kg]	order reference G-Thread	order reference NPT-Thread
10	70	1/4"	1.6	1.9	1.9	1/4 BSPP	1/4" NPT
10	70	3/8"	2.2	2.6	1.9	3/8 BSPP	3/8" NPT
15	85	1/2"	4.3	5.0	2.2	1/2 BSPP	1/2" NPT
20	100	3/4"	6.7	7.8	2.4	3/4 BSPP	3/4" NPT
25	115	1"	11.5	13.4	3.1	1 BSPP	1" NPT
40	130	1-1/4"	20.6	23.9	6.5	1-1/4 BSPP	1-1/4" NPT
40	130	1-1/2"	22.6	26.3	6.5	1-1/2 BSPP	1-1/2" NPT
50	155	2"	37.1	43.2	9.0	2 BSPP	2" NPT

* These figures refer to measurements for the flow direction.

** w.a. = without actuator