

Fire Safe Valves

Type 01651 - Globe Valve



Cryogenic-Globe and Globe/Check Valves, PN50 (DN65=PN45)
"Fire safe" type test approval acc. to EN ISO 10497

Stainless steel body and topwork, "live loaded" gland packing
 "cleaned and degreased for oxygen service"

Part No. 01651.X.000*

Part No. 01651.X.500* Globe/Check Valve

* Butt weld connection for stainless steel pipes acc. to ISO 1127 or ASTM A312

Part No. 01651.X.0004

Part No. 01651.X.5004 Globe/Check Valve

Socket weld connection for stainless steel pipes acc. to ISO 1127 or ASTM A312

Available options - on request only:

- Welded stainless steel stubs acc. to ISO 1127 or ASTM A312 - length FF + 200mm
- Valve with control disc (tapered design)



Applications:

Approved for air gases, vapours and cryogenic liquefied gases incl. LNG.

Working temperature: -196°C / -321°F (77K) up to +120°C / +248°F (393K)

Recommended working temperature: -60°C / -76°F (213K) up to +120°C / +248°F (393K)

Materials	DIN EN	ASTM
1 Body	1.4308	A 351 CF8
2 Valve seal	PTFE / Carbon filled (25%)	
3 Disc	1.4301	A 276 Grade 304
4 Bonnet gasket	Graphite	
5 Headpiece	1.4301 / 1.4308	A 276 Grade 304 / A 351 CF8
6 Bolts	1.4301/A2	A 194 B8
8 Stem	1.4301	A 276 Grade 304
9 Gland packing	Graphite / PTFE / MICA	
10 Gland nut	1.4305	A 276 Grade 303
11 Handwheel	1.4409	A 351 CF3M
12 Spring	1.4310	A 313 Grade 301
13 Bush	CW452K	B 159 UNS C51900

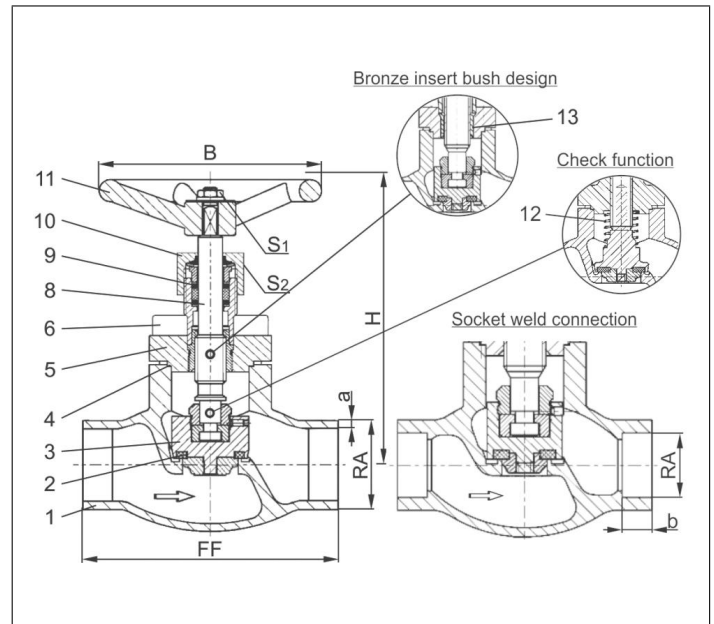

Type 01651 - Standard design	Technical data													
	Nominal size	DN	10	15	15	20	25	32	40	40	50	65	80	100
Dimension code	.X.	1012	1517	1521	2026	2533	3238	4042	4048	5060	657x	8088	0114	
Face-to-face dimension	FF	70	85	85	100	115	115	130	130	155	205	245	280	
Height	H	140	140	140	140	140	170	175	175	200	260	310	350	
Outside pipe-Ø ISO 1127	RA	12.0	17.2	21.3	26.9	33.7	38.0	42.4	48.3	60.3	76.1	88.9	114.3	
Wall thickness pipe ISO 1127	a	1.0	1.6	2.0	2.0	2.0	2.0	2.0	2.0	2.0	2.9	3.2	6.0	
Outside pipe-Ø ASTM A312	RA	13.72	17.15	21.34	26.67	33.40	-	42.16	48.26	60.33	73.03	88.90	114.3	
Wall thickness pipe ASTM A312	a	dimensions acc. to S10 or S40												
Socket depth	b	6	10	10	13	13	-	13	13	16	16	16	20	
Handwheel-Ø	B	100	100	100	100	100	125	125	125	125	200	250	315	
Wrench size across flats	S ₁	7	7	7	7	7	10	10	10	10	10	10	12	
Wrench size across flats	S ₂	30	30	30	30	30	36	36	36	36	36	36	41	
Weight	ca. kg	1.0	1.25	1.3	1.7	2.0	2.8	4.2	4.2	6.7	10.7	16.0	23.0	
Kvs-Value	m ³ /h	1.6	3.8	4.3	6.7	11.5	14.0	20.6	22.6	37.1	71.1	104.0	170.0	
Cv-Value	gal/min	1.9	4.4	5.0	7.8	13.4	16.2	23.9	26.3	43.2	82.9	121.3	198.3	

Dimensions in mm.