

# Offshore Valves

## Type 01741 - Globe Valve



### Cryogenic Globe Valves, DN200

Stainless steel body and topwork  
"live loaded" gland packing

**Part No. 01741.0219.001\* (H=560), PN20**

**Part No. 01741.0219.006\* (H=1000), PN20/PN25**

\*Butt weld connection for stainless steel pipes acc. to ISO 1127 or ASTM A312

**Part No. 01741.0219.00\*4, PN25**

Socket weld connection for stainless steel pipes acc. to ISO 1127 or ASTM A312

In flow direction, the valve with the nominal size DN200 is conform to tightness class L1 up to 9 bar maximum differential pressure acc. to DIN 12567 for LNG use. This standard can also be used for the tightness class of other cryogenic gases.

Available options - on request only

### Applications:

Approved for air gases, vapours and cryogenic liquefied gases incl. LNG.

Working temperature: -196°C / -321°F (77K) up to +120°C / +248°F (393K)



Materials	DIN EN	ASTM
1 Body	1.4409	A 351 CF3M
2 Valve seal	PCTFE (Kel-F)	
3 Disc	1.4404	A 276 Grade 316L
4 Bonnet gasket	Graphite	
5 Headpiece	1.4404	A 276 Grade 316L
6 Bolts	1.4571/A4	similar A 194 B8T
7 Elongation tube	1.4571	A 213 TP 316Ti
8 Stem	1.4404	A 276 Grade 316L
9 Gland packing	Graphite / PTFE / MICA	
10 Gland nut	1.4404	A 276 Grade 316L
11 Handwheel	1.4571	A 213 TP 316Ti
13 Bush	CW452K	B 159 UNS C51900

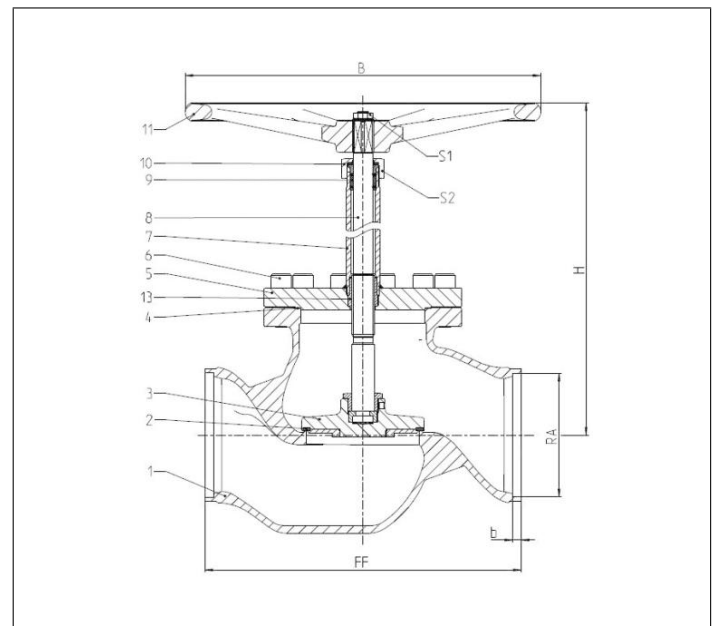

Type 01741 - Standard design	Technical data	
Nominal size	DN	200
Dimension code	.X.	0219
Face-to-face dimension	FF	560
Height	H	560
Outside pipe-Ø ISO 1127	RA	219.1
Wall thickness pipe ISO 1127	a	6.3
Outside pipe-Ø ASTM A312	RA	219.1
Wall thickness pipe ASTM A312	a	dimensions acc. to S10 or S40
Socket depth	b	15
Handwheel-Ø	B	630
Wrench size across flats	S <sub>1</sub>	30
Wrench size across flats	S <sub>2</sub>	65
Weight	ca. kg	135
Kvs-Value	m <sup>3</sup> /h	680
Cv-Value	gal/min	793

Dimensions in mm.