

Spare Parts for Valves and Fill Cluster

Type 01950 - Topwork



for Liquid Cylinder Valves

"cleaned and degreased for oxygen service"

Part No. 01950.XXXX.EXXXXX

Handwheel colors: green, blue or grey

Available options - on request only:

- Printed hub cap with customised design
- Additional handwheel color

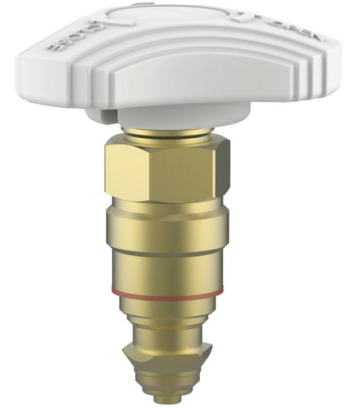

Materials	DIN EN	ASTM
1 Bonnet	CW614N	B 283 UNS C38500
2 Gasket	Copper	
3 Stem seal gasket	PTFE	
4 Upper stem	CW614N	B 283 UNS C38500
5 Lower spindle	CW614N	B 283 UNS C38500
6 Disc	PCTFE	
7 V packing	PTFE	
8 Gland packing	PTFE	
9 Top washer	PTFE	
10 Handwheel	C.Alum. + P.C.	
11 Disc washer	1.4301	A 276 Grade 304
12 Flat washer	1.4301	A 276 Grade 304
13 Hub cap	Mild steel zinc plated + powder coating	
14 Nyloc nut	1.4301	A 276 Grade 304

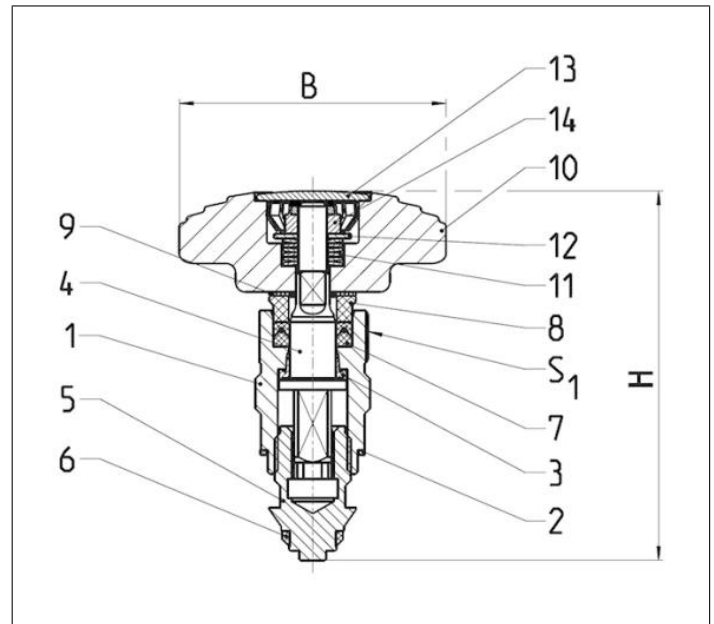

Type 01950	Technical data				
Nominal size	DN	6	8	10	15
Handwheel-Ø	B	67	67	67	67
Wrench size across flats	S ₁	22	22	22	22
Weight	ca. kg	0.3	0.3	0.3	0.3

Dimensions in mm.