

Globe Valves

Type 03252 - Bellow Sealed Globe Valve



Cryogenic-Bellow Sealed Globe Valve, PN40

Stainless steel body and topwork,
 "live loaded" gland packing
 "cleaned and degreased for oxygen service"

Part No. 03252.X.0022

Flanged connection acc. to DIN EN 1092-1 PN40

Available options - on request only:

- Extension H up to 900mm
- Valve with control disc (tapered design)



Applications:

Approved for air gases, vapours and cryogenic liquefied gases incl. LNG.
 Working temperature: -196°C / -321°F (77K) up to +120°C / +248°F (393K)
 Leak rate: 10⁻⁶ mbar ltr / sec outside, 10⁻⁴ mbar ltr / sec seat

Materials	DIN EN	ASTM
1 Body	1.4308	A 351 CF8
2 Valve seal	PTFE / Carbon filled (25%)	
3 Disc	1.4301	A 276 Grade 304
4 Bonnet gasket	PTFE	
5 Headpiece	1.4301	A 276 Grade 304
6 Bellow stem	1.4571	A 276 Grade 316Ti
7 Bolts	1.4301/A2	A 194 B8
8 Bellow	1.4571	A 276 Grade 316Ti
9 Elongation tube	1.4541	A 213 TP 321
10 Headpiece	1.4301	A 276 Grade 304
11 Bush	CW452K	B 159 UNS C51900
12 Stem	1.4301	A 276 Grade 304
13 Gland packing	Graphite / PTFE / MICA	
14 Gland nut	1.4305	A 276 Grade 303
15 Handwheel	Aluminium alloy	

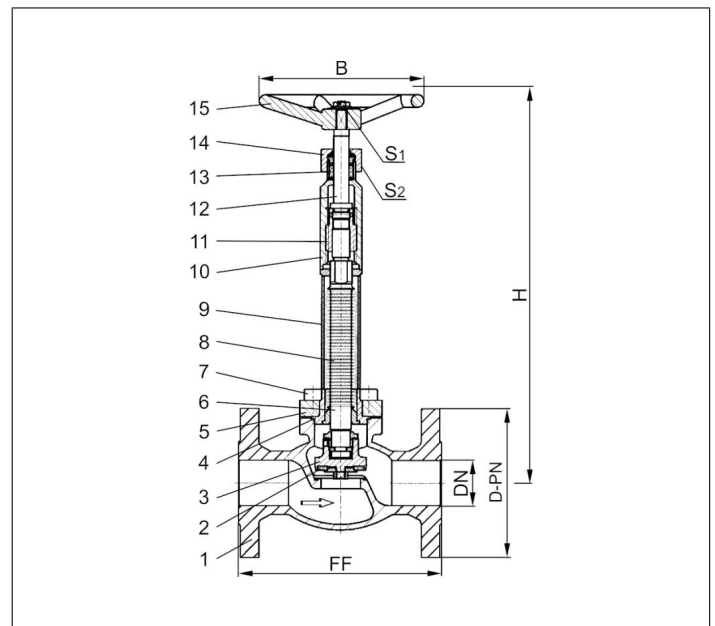

Type 03252 - Standard design	Technical data					
Nominal size	DN	15	20	25	40	50
Dimension code - Flange EN 1092-1 PN40	.X.	0150	0200	0250	0400	0500
Flange-Ø	D-PN	95	105	115	150	165
Face-to-face dimension	FF	140	150	160	200	230
Height	H	380	380	380	380	380
Handwheel-Ø	B	150	150	150	150	150
Wrench size across flats	S ₁	7	7	7	10	10
Wrench size across flats	S ₂	30	30	30	36	36
Weight	ca. kg	3.5	5.0	5.2	10.1	13.8
Kvs-Value	m ³ /h	4.3	6.7	11.5	22.6	37.1
Cv-Value	gal/min	5.0	7.8	13.4	26.3	43.2

Dimensions in mm.