

Offshore Valves

Type 03741 - Globe Valve, ASME B16.5 Flanges



Cryogenic Globe Valves, class 150

Stainless steel body and topwork,
"live loaded" gland packing

Part No. 03741.8000.0011 (H=560)

Flanged connection acc. to ASME B16.5 class 150

In flow direction, the valve with the nominal size DN200 is conform to tightness class L1 up to 12 bar maximum differential pressure acc. to DIN 12567 for LNG use. This standard can also be used for the tightness class of other cryogenic gases.

Available options - on request only



Applications:

Approved for air gases, vapours and cryogenic liquefied gases incl. LNG.

Working temperature: -196°C / -321°F (77K) up to +120°C / +248°F (393K)

Materials	DIN EN	ASTM
1 Body	1.4409	A 351 CF3M
1a Flange	1.4404	A 276 Grade 316L
2 Valve seal	PCTFE (Kel-F)	
3 Disc	1.4404	A 276 Grade 316L
4 Bonnet gasket	Graphite	
5 Headpiece	1.4404	A 276 Grade 316L
6 Bolts	1.4571/A4	similar A 194 B8T
7 Elongation tube	1.4571	A 213 TP 316Ti
8 Stem	1.4404	A 276 Grade 316L
9 Gland packing	Graphite / PTFE / MICA	
10 Gland nut	1.4404	A 276 Grade 316L
11 Handwheel	1.4571	A 213 TP 316Ti
12 Spring	1.4571	A 313 Grade 316Ti
13 Bush	CW452K	B 159 UNS C51900

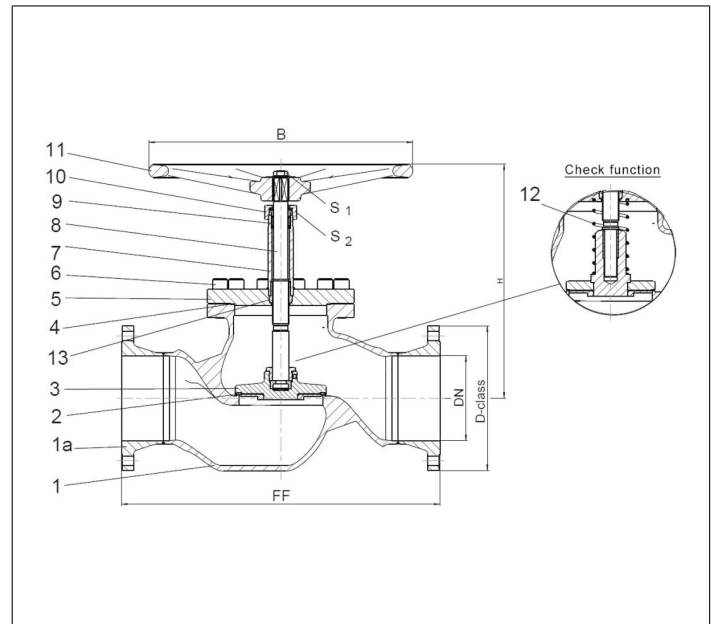

Type 03741 - Standard design	Technical data	
Nominal size	DN	200
Dimension code	.X.	8000
Flange-Ø	D-class	345
Face-to-face dimension	FF	760
Height	H	560
Handwheel-Ø	B	630
Wrench size across flats	S ₁	30
Wrench size across flats	S ₂	65
Weight	ca. kg	135
Kvs-Value	m ³ /h	680
Cv-Value	gal/min	793

Dimensions in mm.