

Check Valves

Type 05411 - Check Valve



Cryogenic-Check Valves, PN50

Bronze body and cap
with spring, opening pressure ca. 0.1 bar
"cleaned and degreased for oxygen service"

Part No. 05411.X.0008

Completed with union type braze fittings for copper pipes acc. to DIN EN 12449 or ASTM B88

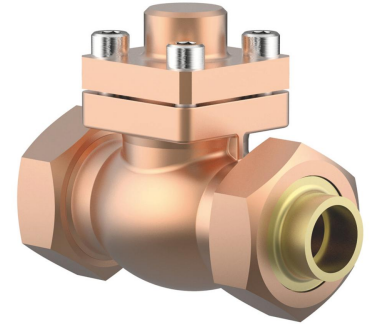

Applications:

Approved for air gases, vapours and cryogenic liquefied gases incl. LNG.
Working temperature: -196°C / -321°F (77K) up to +120°C / +248°F (393K)

Materials	DIN EN	ASTM
1 Body	CC491K	B 62 UNS C83600
2 Valve seal	PTFE / Carbon filled (25%)	
3 Disc	CW614N	B 283 UNS C38500
4 Spring	CW452K	B 159 UNS C51900
5 Bonnet gasket	PTFE	
6 Bolts	1.4301/A2 A 194 B8	
7 Cap	CC493K	B 505 UNS C93200
8 Braze fitting	CC493K	B 505 UNS C93200
9 Union nut	CC493K	B 505 UNS C93200

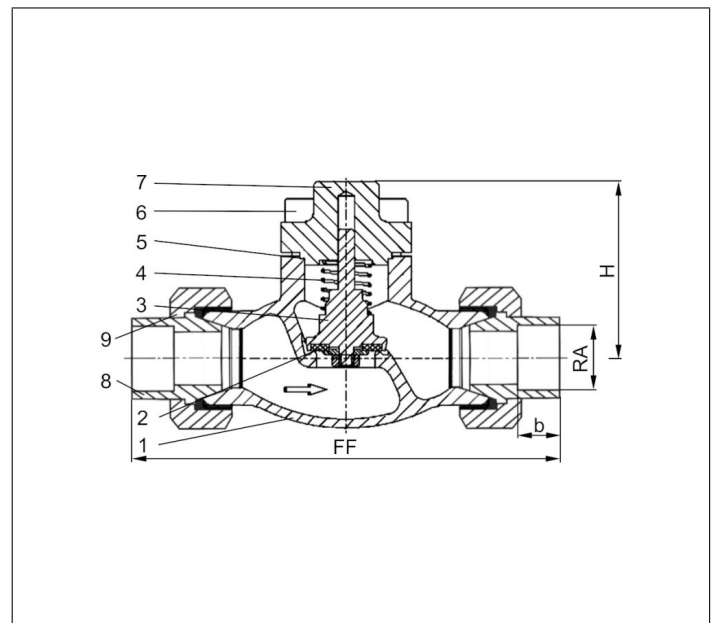

Type 05411 - Standard design	Technical data								
Nominal size	DN	10	10	20	20	32	32	40	50
Dimension code	.X.	1012	1015	1518	2022	2528	3235	4042	5054
Face-to-face dimension	FF	98	98	132	132	171	171	230	230
Height	H	71	71	72	72	87	87	95	95
Outside pipe-Ø	RA	12.0	15.0	18.0	22.0	28.0	35.0	42.0	54.0
Socket depth	b	11	11	14	14	17	17	17	17
Weight	ca. kg	0.9	0.9	2.0	2.0	3.6	3.6	6.0	8.5
Kvs-Value	m ³ /h	1.6	2.2	6.0	6.7	11.5	12.1	22.6	37.1
Cv-Value	gal/min	1.9	2.6	7.1	7.8	13.4	14.1	26.3	43.2

Dimensions in mm. Leakage rates will be provided on request