

Offshore Valves

Type 05714 - Check Valve



Cryogenic-Check Valves

Stainless steel body and cap
with spring, opening pressure ca. 0.1 bar

Part-No. 05714.X.0051, PN25

Butt weld connection for stainless steel pipes acc. to ISO 1127 or ASTM A312

Part-No. 05714.X.0054, PN25

Socket weld connection for stainless steel pipes acc. to ISO 1127 or ASTM A312

Available options - on request only

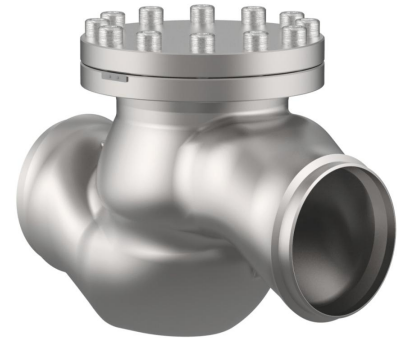

Applications:

Approved for hydrogen, air gases, vapours and cryogenic liquefied gases incl. LNG.

Working temperature: -255°C / -427°F (18K) up to +120°C / +248°F (393K)

Materials	DIN EN	ASTM
1 Body	1.4409	A 351 CF3M
2 Valve Seal	PTFE	
3 Disc	1.4404	A 276 Grade 316L
4 Spring	1.4571	A 313 Grade 316Ti
5 Bonnet gasket	Graphite	
6 Bolts	A4-80	A 194 B8
7 Cap	1.4404	A 276 Grade 316L

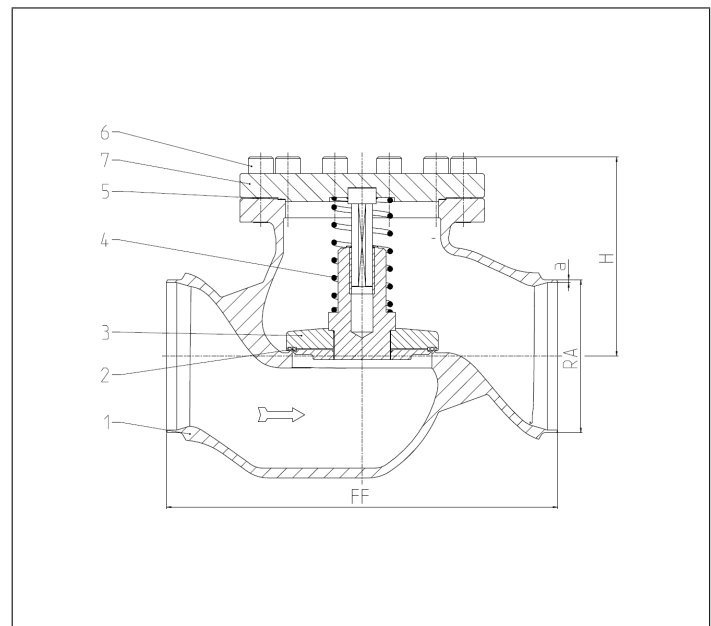

Type 05714 - Standard design	Technical data	
Nominal size	DN	200
Dimension code	.X.	0219
Face-to-face dimension	FF	560
Height	H	285
Outside pipe-Ø ISO 1127	RA	219,1
Wall thickness pipe ISO 1127	a	6,3
Outside pipe-Ø ASTM A312	RA	219,1
Wall thickness pipe ASTM A312	a	dimensions acc. to S10 or S40
Socket depth	b	15
Weight	ca. kg	109
Kvs-Value	m ³ /h	680
Cv-Value	gal/min	786

Dimensions in mm. Leakage rates will be provided on request