

Offshore Valves

Type 05719 - Check Valve, ASME B16.5 Flanges



Tieftemperatur-Rückschlagventile, class 150

Stainless steel body and cap
with spring, opening pressure ca. 0.1 bar
"cleaned and degreased for oxygen service"

Part-No. 05719.X.0051

Flanged connection acc. to ASME B16.5 class 300
Disc seal: PTFE

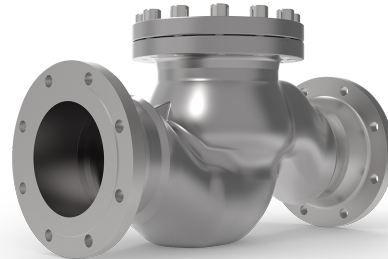

Applications:

Approved for hydrogen, air gases, vapours and cryogenic liquefied gases incl. LNG.
Working temperature: -255°C / -427°F (18K) up to +120°C / +248°F (393K)

Materials	DIN EN	ASTM
1 Body	1.4409	A 351 CF3M
2 Valve seal	PTFE	
3 Disc	1.4404	A 276 Grade 316L
4 Spring	1.4571	A 313 Grade 316Ti
5 Bonnet gasket	Graphite	
6 Bolts	1.4571/A4	similar A 194 B8T
7 Cap	1.4404	A 276 Grade 316L
7a Bush from DN65	PTFE	

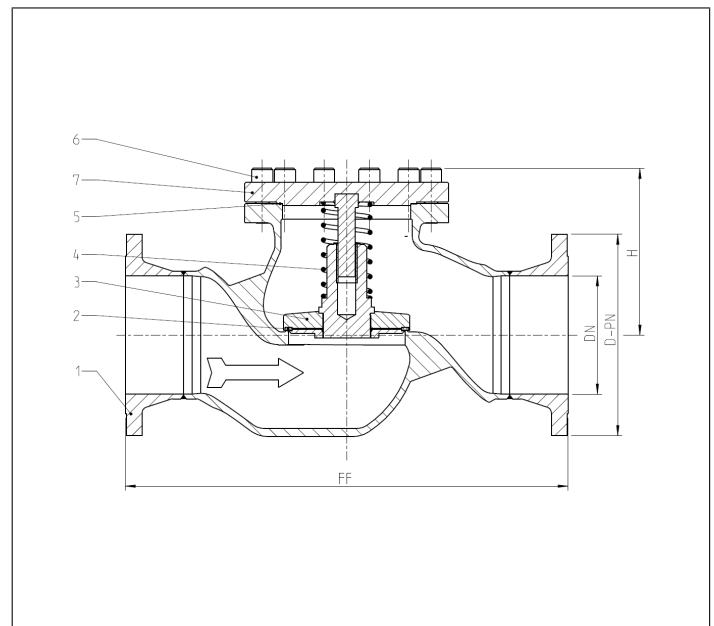

Type 05719 - Standard design	Technical data	
Nominal size	DN	200
Dimension code - Flange ASME B16.5 class 150	.X.	0219
Flange-Ø	D-class	345
Face-to-face dimension	FF	760
Height	H	285
Weight	ca. kg	146
Kvs-Value	m ³ /h	680.0
Cv-Value	gal/min	793.0

Dimensions in mm. Leakage rates will be provided on request