

Check Valves

Type 05C02 - Check Valve



**Top-Entry Cryogenic-Check-Valves, forged steel body, up to PN63
A005 series**

Stainless steel body and topwork,
" with spring, opening pressure ca. 0.1 bar "
" cleaned and degreased for oxygen service "

Part-No. 05C02.A005.X

Butt weld connection for stainless steel pipes acc. to ISO 1127 or ASTM A312

Available options:

- Purge port
- on request only:
- Further connection types



Application:

Approved for hydrogen, air gases, vapours and cryogenic liquefied gases incl. LNG.
Working temperature: -269°C / -452°F (4K) up to +80°C / +176°F (353K)

Materials	DIN EN	ASTM
1 Body	1.4571	A 313 Grade 316TI
2 Valve Seal	PTFE	PTFE
3 Disc	1.4571	A 313 Grade 316TI
4 Spring	1.4571	A 313 Grade 316TI
5 Tube	1.4571	A 313 Grade 316TI
6 Pipe	1.4571	A 313 Grade 316TI
7 Flange	1.4404	A 276 Grade 316L
8 Gasket	PTFE	PTFE
9 Cap	1.4404	A 276 Grade 316L
10 Bolt	A4-80	A 194 B8M

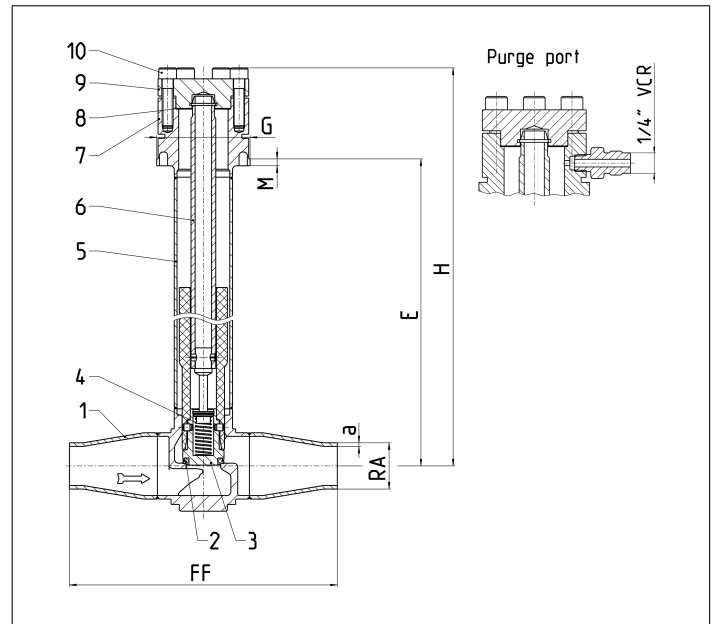

Type 05C02	Technical data		
Nominal size	DN	25	25
Dimension code	.X.	000001	000004
Face-to-face dimension	FF	150	150
Height	H	392	392
Collar-Ø	G	68	68
Length	M	5	5
Length	E	325	325
Outside pipe-Ø ISO	Ra	33.7	33.7
Wall thickness pipe ISO	a	2,6	2,6
Pipe-Ø ASTM A312		1" S10	1" S10
KVS-Value	m ³ /h	10.4	10.4
CV-Value	gal/min	12.0	12.0
Weight		3.6 kg	3.6 kg
Purge port		without	1/4" VCR

Dimensions in mm.