

Safety Valves

Type 06001



Cryogenic Safety Valves, angle type, brass, PN63, type tested TÜV-SV.1048. S/G/L

Standard Safety Valve,
complete with carbon filled PTFE valve seal, closed bonnet
Outlet: female thread Rc 3/8 acc. to ISO 7/1
"cleaned and degreased for oxygen service"

Part No. 06001.X.0000

Inlet: male thread type R (BSPT) acc. to ISO 7/1

Part No. 06001.X.2000

Inlet: male thread type G (BSPP) acc. to ISO 228/1

Part No. 06001.X.5000

Inlet: male thread NPT acc. to ANSI B 1.20.1

Available options - on request only:

- with installed elbow at the outlet



Applications:

Provided as safety device for protection against thermal expansion in pipeworks and parts of facilities.

Approved for air gases, vapours and cryogenic liquefied gases incl. LNG.

Working temperature: -196°C / -321°F (77K) up to +65°C / +149°F (338K), suitable for horizontal installation

Materials	DIN EN	ASME/ASTM
1 Body	CW617N	EN12165 CW617N Code Case 1750
2 Disc	PTFE / Carbon filled (25%)	
3 Guide plate	CW614N	EN12164 CW614N Code Case 1750
4 Stem	CW614N	EN12164 CW614N Code Case 1750
5 Spring	1.4571	A 313 Grade 316Ti
6 Bonnet	CW614N	EN12164 CW614N Code Case 1750
7 Spring clamp	CW614N	EN12164 CW614N Code Case 1750
8 Thread ring	CW614N	EN12164 CW614N Code Case 1750
9 Cap	CW614N	EN12164 CW614N Code Case 1750

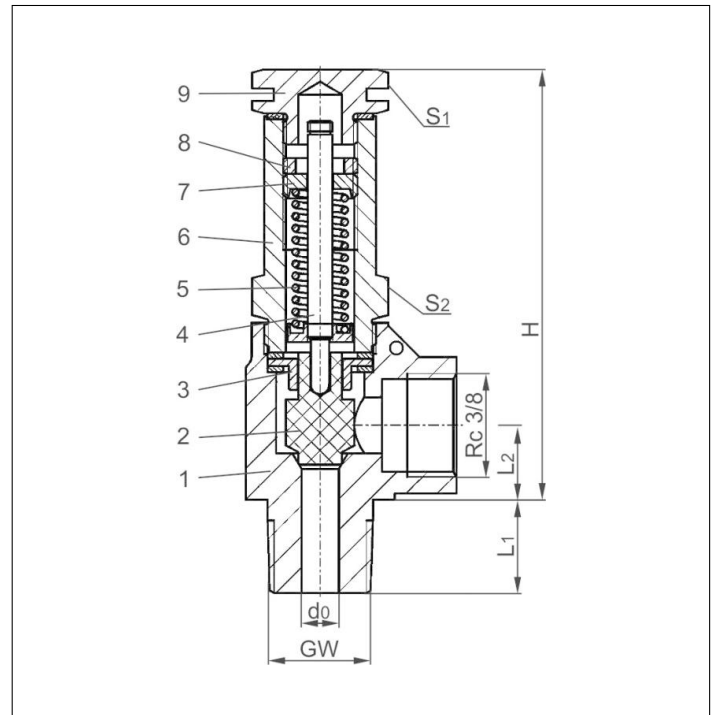

Type 06001	Technical data			
Nominal size	GW	1/4	3/8	1/2
Orifice	d ₀	6.0	6.0	6.0
Dimension code	.X.	0200	0300	0400
Set pressure range	bar	5.0-55.0	5.0-55.0	5.0-55.0
Height	H	70	70	70
Length	L ₁	13	15	17
Length	L ₂	13	13	13
Wrench size across flats	S ₁	19	19	19
Wrench size across flats	S ₂	19	19	19
Weight	ca. kg	0.18	0.195	0.21
Coefficient of discharge	α _w	0.09	0.09	0.09

Dimensions in mm.

Safety Valves

Type 06001



Discharge capacities

Calculation of flow rate acc. to AD2000-Merkblatt A2 / DIN EN ISO 4126-1

Medium:

Air in m³/h at 0°C and 1013.25 mbar

Water in kg/h

The capacity indicated below is for a fully opened valve.

d_0 - orifice

A_0 - flow area

Set pressure in bar (g)	GW	1/4, 3/8 & 1/2	1/4, 3/8 & 1/2
	d_0 (mm)	6.0	6.0
	A_0 (mm ²)	28.3	28.3
	Medium	Air	Water
5.0		11	304
6.0		13	333
7.0		15	360
8.0		17	384
9.0		19	408
10.0		21	430
12.0		25	471
14.0		29	508
16.0		33	544
18.0		36	577
20.0		41	608
22.0		45	637
24.0		48	666
26.0		52	693
28.0		56	719
30.0		61	744
32.0		65	769
34.0		68	792
36.0		72	815
38.0		76	838
40.0		81	859
42.0		85	881
44.0		89	901
46.0		93	922
48.0		97	941
50.0		102	961
52.0		106	980
54.0		110	999
55.0		112	1008