

Safety Valves

Type 06386



Cryogenic Safety Valves, angle type, bronze, PN40, type tested TÜV-SV.780. S/G

Standard safety valve (0.2 - 25.0/40.0 bar). **ASME certification only for d₀ 10.5**

Metal to metal seated, closed bonnet

"cleaned and degreased for oxygen service"

Part No. 06386.X.0000

Inlet: male thread type G (BSPP) acc. to ISO 228/1, Outlet: female thread type G (BSPP) acc. to ISO 228/1

Part No. 06386.X.2000

Inlet: male thread type R (BSPT) acc. to ISO 7/1, Outlet: female thread type G (BSPP) acc. to ISO 228/1

Part No. 06386.X.5000

Inlet: male thread NPT acc. to ANSI B 1.20.1, Outlet: female thread type G (BSPP) acc. to ISO 228/1

Part No. 06386.X.6000

Inlet: male thread NPT acc. to ANSI B 1.20.1, Outlet: female thread NPT acc. to ANSI B 1.20.1

Available options - on request only:

- external parts nickel plated
- with installed elbow at the outlet



Applications:

Provided as safety device for protection against excessive pressure in stationary and moveable gas cylinders and pressure vessels. Approved for air gases, vapours and cryogenic liquefied gases incl. LNG.

Working temperature: -196°C / -321°F (77K) up to +185°C / +365°F (458K)

Materials	DIN EN	ASME/ASTM
1 Outlet body	CC491K	B 62 UNS C83600
2 Inlet body	1.4301	A 276 Grade 304
4 Disc	1.4541	A 276 Grade 321
5 Guide plate	CW453K	B 103 UNS C52100
6 Stem	CW453K	B 103 UNS C52100
7 Spring	1.4571	A 313 Grade 316Ti
8 Bonnet	1.4308	A 351 CF 8
9 Spring clamp	CW614N	B 283 UNS C38500
10 Thread ring	CW614N	B 283 UNS C38500
11 Cap	CW614N	B 283 UNS C38500

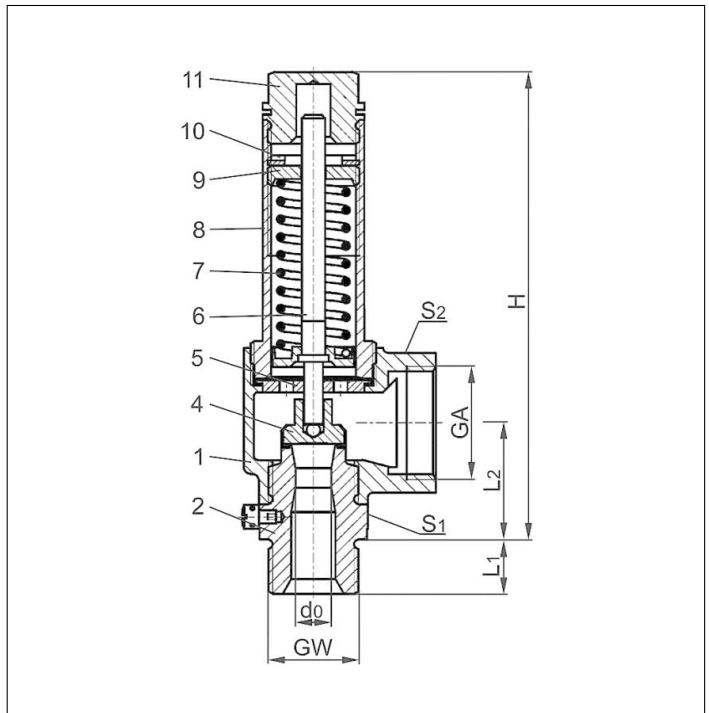

Type 06386	Technical data			
Nominal size	GW	1/2	3/4	1
Orifice	d ₀	10.5	10.5	14.0
Dimension code	.X.	1004	1006	1410
Set pressure range	bar	0.2-25.0	0.2-25.0	0.2-40.0
Outlet	GA	1	1	1-1/4
Height	H	140	140	157
Length	L ₁	14	16	18
Length	L ₂	36	36	42
Wrench size across flats	S ₁	30	30	41
Wrench size across flats	S ₂	41	41	50
Weight	ca. kg	0.75	0.78	1.24
Coeff. of discharge from 3.0 bar	α _w	0.67	0.67	0.67

Dimensions in mm.

Safety Valves

Type 06386



Discharge capacities

Medium:

Air in m³/h at 0°C and 1013.25 mbar

Air in SCFM at 60°F (15.6°C) and 14.7 psia (1013.25 mbar)

The capacity indicated below is for a fully opened valve.

d₀ - orifice

A₀ - flow area

Calculation of discharge capacity acc. to AD2000-Merkblatt A2 / DIN EN ISO 4126-1 resp. ASME Code Sec. VIII.

Set pressure in bar (g)	GW	1/2 & 3/4	1
	d ₀ (mm)	10.5	14
	A ₀ (mm ²)	86.6	153.9
	Medium	Air in m ³ /h	
0.2		25	49
0.5		48	87
1.0		75	135
1.5		100	176
2.0		124	217
3.0		171	304
4.0		214	381
5.0		259	460
6.0		302	537
7.0		346	615
8.0		391	695
9.0		434	772
10.0		479	852
12.0		567	1008
14.0		655	1164
16.0		742	1320
18.0		830	1476
20.0		927	1648
22.0		1015	1805
24.0		1104	1963
25.0		1148	2041
26.0		-	2120
28.0		-	2278
30.0		-	2458
32.0		-	2617
34.0		-	2776
36.0		-	2935
38.0		-	3094
40.0		-	3281

Set pressure in psig	GW	1/2 & 3/4
	d ₀ (inch)	0.413
	A ₀ (in ²)	0.134
	Medium	Air in SCFM
30		81
40		100
50		118
60		137
70		156
80		175
90		193
100		212
120		249
140		287
160		324
180		362
200		399
220		436
240		474
260		511
280		549
300		586
320		623
340		661
363		704