

Strainers

Type 08415 - Strainer



Cryogenic-Strainer, PN50

Stainless steel body and bronze cap
with strainer screen mesh size 0.25 mm
"cleaned and degreased for oxygen service"

Part No. 08415.X.0001

Female thread connection (G) acc. to ISO 228/1

Part No. 08415.X.0006

Female thread connection NPT acc. to ANSI B 1.20.1

Available options - on request only:

- Female thread connection (R) acc. to ISO 7-Rc
- other mesh sizes for strainer screen (changed flow coefficient)
- strainer screen in bronze or monel
- sintered filter in bronze or stainless steel in various porosities

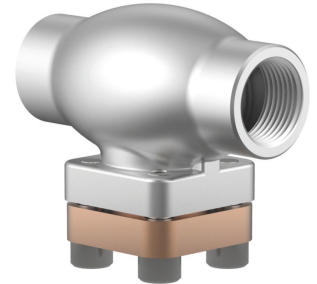

Applications:

Approved for air gases, vapours and cryogenic liquefied gases incl. LNG.

Working temperature: -196°C / -321°F (77K) up to +120°C / +248°F (393K)

Materials	DIN EN	ASTM
1 Body	1.4308	A 351 CF8
2 Sieb	1.4301	A 240 Grade 304
3 Bonnet gasket	PTFE	
4 Capschrauben	1.4301/A2	A 194 B8
5 Cap	CC493K	B 505 UNS C93200

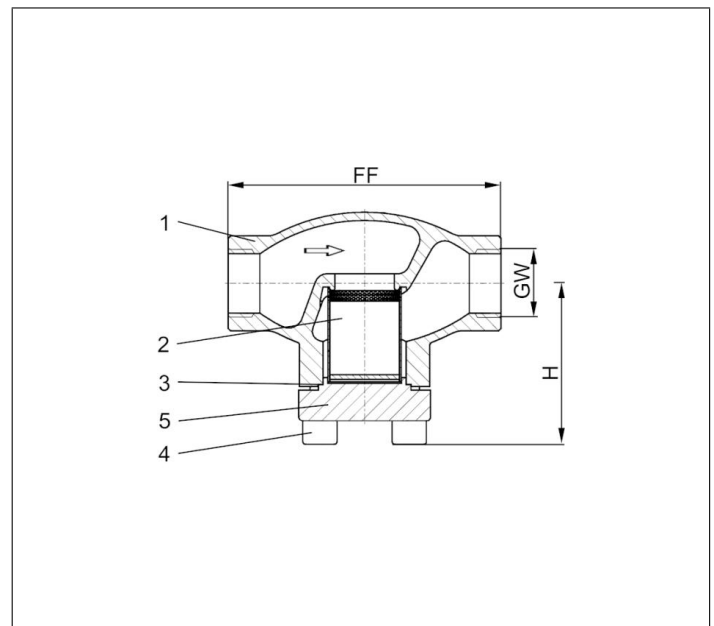

Type 08415 - Standard design	Technical data								
Nominal size	DN	10	10	15	20	25	40	40	50
Thread size	GW	1/4	3/8	1/2	3/4	1	1-1/4	1-1/2	2
Dimension code	.X.	0200	0300	0400	0600	1000	1200	1400	2000
Face-to-face dimension	FF	70	70	85	100	115	130	130	155
Height	H	62	62	62	65	69	89	89	89
Weight	ca. kg	0.6	0.6	0.8	0.9	1.2	3.1	3.1	4.7
Kvs-Value	m ³ /h	1.5	1.5	3.4	6.5	9.5	19.0	21.0	28.0
Cv-Value	gal/min	1.7	1.7	3.9	7.5	11.0	22.0	24.3	32.4

Dimensions in mm.