

Gate Valves

Type 09440 - Gate valve



Cryogenic-Gate Valves, PN50

Stainless steel body and topwork,
 one way tightening (in flow direction),
 "live loaded" gland packing
 "cleaned and degreased for oxygen service"

Working pressure: 5 - 50 bar, Leakage rate A acc. to DIN EN 12266
 Working pressure: 0.7 - 4.9 bar, Leakage rate B acc. to DIN EN 12266

Part No. 09440.X.002*

Completed with union type butt weld fittings for stainless steel pipes
 acc. to ISO 1127 or ASTM A312

Available options - on request only:

- Further pipe wall thicknesses



Applications:

Approved for air gases, vapours and cryogenic liquefied gases incl. LNG.
 Working temperature: -196°C / -321°F (77K) up to +120°C / +248°F (393K)

Materials	DIN EN	ASTM
1 Body	1.4308	A 351 CF8
2 Valve seal	PTFE / Carbon filled (25%)	
3 Disc	CW452K	B 159 UNS C51900
4 Wedge	1.4308	A 351 CF8
5 Stem	1.4301	A 276 Grade 304
6 Bonnet gasket	PTFE	
7 Headpiece	1.4301	A 276 Grade 304
8 Bolts	1.4301/A2	A 194 B8
9 Elongation tube	1.4541	A 213 TP 321
10 Gland packing	Graphite / PTFE / MICA	
11 Gland nut	1.4305	A 276 Grade 303
12 Handwheel	Aluminium alloy	
13 Bush	CW452K	B 159 UNS C51900
14 Weld fitting	1.4301	A 276 Grade 304
15 Union nut	1.4301	A 276 Grade 304

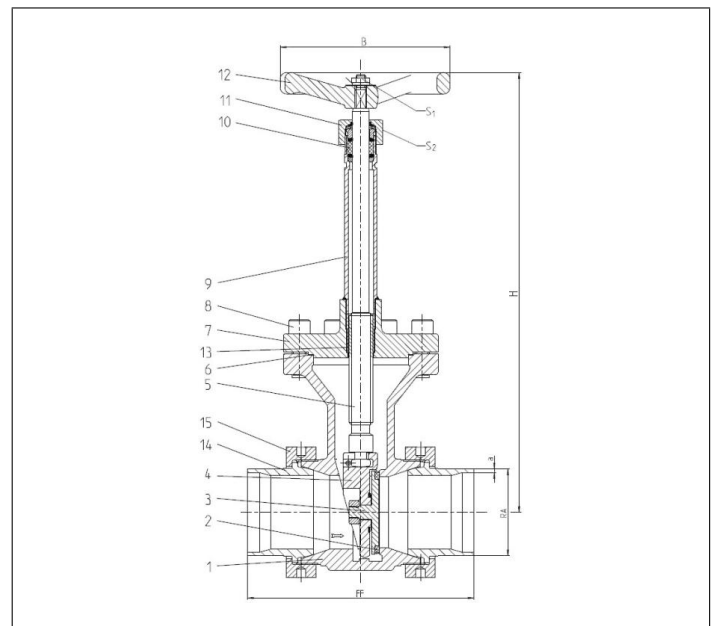

Type 09440 - Standard design	Technical data				
Nominal size	DN	25	40	50	65
Dimension code	.X.	2533	4048	5060	657x
Face-to-face dimension	FF	193	193	170	160
Height	H	330	360	410	440
Outsid pipe-Ø ISO 1127	RA	33.7	48.3	60.3	76.1
Wall thickness pipe ISO 1127	a	2.0	2.0	2.0	2.6
Outsid pipe-Ø ASTM A312	RA	33.40	48.26	60.33	73.03
Wall thickness pipe ASTM A312	a	dimensions acc. to S10 or S40			
Handwheel-Ø	B	125	125	150	150
Weight	ca. kg	3.5	5.1	7.8	9.0
Kvs - Value	m ³ /h	43	93	125	227
Cv - Value	gal/min	51	111	149	264

Dimensions in mm.