

Actuated Valves and Actuators

Type 27514 - Pneumatic Actuator - Globe Valve (On/off and Control Valve)



Pneumatic Actuators for Type 11C01 - Globe Valve FULLX

Actuator - **spring to close**, air to open
 maximum air pressure for operation 6.0 bar
 Actuator coating: Delta Seal GZ (silver-grey)
 Corrosion-protection class C5-M acc. to DIN EN ISO 12944
 Available options - on request only:
 · Pneumatic actuator with override handwheel

Ambient temperature limit: -40°C / -40°F (233K) up to +100°C / 212°F (373K)



Materials	DIN EN	ASTM
1 Body	1.0335	A 622 Grade 1008
2 Diaphragm	NBR + tissue	
3 Springs	1.4310	A 313 Grade 301
4 Actuator stem	1.4571	A 276 Grade 316Ti
5 Coupling	1.4571	A 276 Grade 316Ti

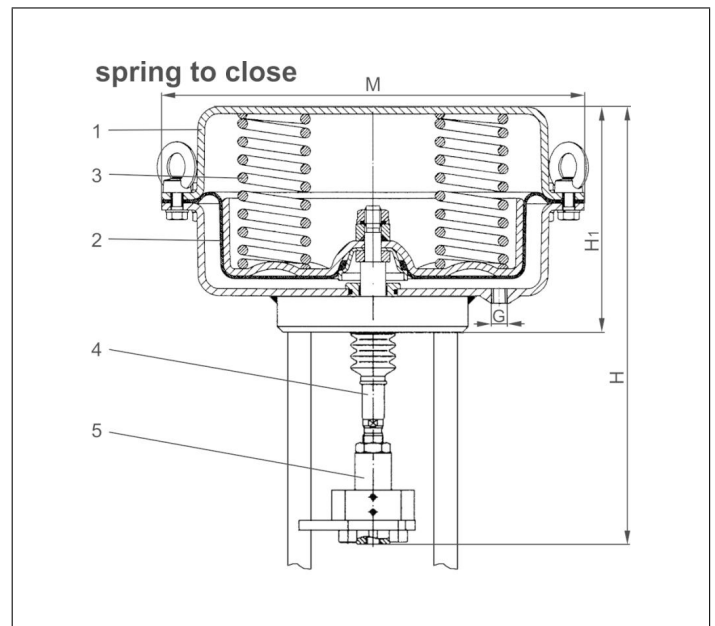

Type 27514		Technical Data								
Part No.	Actuator	27514								
		.DP30 .2022	.DP32 .2008	.DP32 .2020	.DP33 .3020	.DP34 .5015	.DP34 .5020	.DP34 .T0PO	.DP34 .TRPO	.DP34 .TRP1
Diameter Actuator	M	168	250	250	300	405	405	405	405	405
Height	H	ca. 244	ca. 240	ca. 240	ca. 300	ca. 375	ca. 375	ca. 635	ca. 884	ca. 884
Height	H1	122	124	124	166	228	228	450	672	672
Thread	G	G 1/4"	G 1/4"	G 1/4"	G 1/4"	G 3/8"	G 3/8"	G 3/8"	G 1/2"	G 1/2"
Diaphragm area	cm ²	80	250	250	400	800	800	1600 (2x800)	2400 (3x800)	2400 (3x800)
Spring range	bar	2.2 - 4.5	0.8 - 2.4	2.0 - 3.8	2.0 - 4.0	1.5 - 3.0	2.0 - 4.0	2.0 - 4.0	2.0 - 4.0	2.0 - 4.0
Minimum air pressure	bar	4.8	2.7	3.6	4.5	3.3	4.5	4.5	4.5	4.5
Regulating lift	mm	20	20	20	30	50	50	50	65	65
Weight	ca. kg	5.0	9.0	9.0	15.0	45.0	45.0	116.0	150.0	152.0

Dimensions in mm.

Actuated Valves and Actuators

Type 27514 - Pneumatic Actuator - Globe Valve (On/off and Control Valve)



Overview - required actuator sizes for differential pressures

DN	Body**	Differential pressure in bar									
		1,0 - 5,9	6,0 - 9,9	10,0 - 15,9	16,0 - 29,9	30,0 - 35,9	36,0 - 37,9	38,0 - 43,9	44,0 - 49,9	50,0 - 53,9	54,0 - 63,0
10	S/A/Y	A	A	A	A	A	A	A	A	A	A
15	S/A/Y	A	A	A	A	A	A	A	A	A	A
20	S/A/Y	A	A	A	A	A	B	B	B	B	C
25	S/A/Y	A	A	A	A	A	B	B	B	B	C
32	S	B	B	C	C	D	D	D	D	D	D
32	A/Y	E	E	E	E	E	E	E	E	E	E
40	S	B	B	C	C	D	D	D	D	D	D
40	A/Y	E	E	E	E	E	E	E	E	E	E
50	S	B	C	C	D	D	D	D	D	E	E
50	A/Y	E	E	E	E	E	E	E	E	E	E
10*	S/A/Y	A	A	A	A	A	A	A	B	B	B
15*	S/A/Y	A	A	A	A	A	A	A	B	B	B
20*	S/A/Y	A	A	A	A	A	A	B	B	B	B
25*	S/A/Y	A	A	A	A	A	A	B	B	B	B
32*	S/A/Y	B	B	C	C	D	D	D	D	D	D
40*	S/A/Y	B	B	C	C	D	D	D	D	D	D
50*	S/A/Y	B	C	C	D	D	D	D	D	E	E

* with bellows or control version or throttle version, ** S = Straight body, A = Angle type, Y = Y type

The differential pressures are based on the flow direction of the valve.

Differential pressures against the flow direction have to be requested separately.

Code in Table	Part-No. Actuator
A	27514.DP30.2O22
B	27514.DP32.2O08
C	27514.DP32.2O20
D	27514.DP33.3O20
E	27514.DP34.5O15