

Spare Parts for Valves and Fill Cluster

Type 28312 - Topwork Angle Type



for Cryogenic-Globe Valves Angle Type

Bronze topwork
 "live loaded" gland packing
 "cleaned and degreased for oxygen service"

Part No. 28312.X.0010 (H=270mm)

Part No. 28312.X.0020 (H=370mm)

Part No. 28312.X.5010 (H=270mm) with check function

Part No. 28312.X.5020 (H=370mm) with check function

suitable for:

| Type | Nominal size |
|----------------------------|--------------|
| 01322 | DN15 - DN50 |
| 07003 - only angled valves | DN25 & DN40 |
| 07004 - only angled valves | DN25 & DN40 |
| 07015 - only angled valves | DN25 & DN40 |



| Materials | DIN EN | ASTM |
|-------------------|----------------------------|------|
| 1 Valve seal | PTFE / Carbon filled (25%) | |
| 2 Disc | CW614N B 283 UNS C38500 | |
| 3 Bonnet gasket | PTFE | |
| 4 Headpiece | CC493K B 505 UNS C93200 | |
| 5 Bolts | 1.4301/A2 A 194 B8 | |
| 6 Elongation tube | 1.4541 A 213 TP 321 | |
| 7 Stem | 1.4301 A 276 Grade 304 | |
| 8 Gland packing | Graphite / PTFE | |
| 9 Gland nut | CW614N B 283 UNS C38500 | |
| 10 Handwheel | Aluminium alloy | |
| 11 Spring | CW452K B 159 UNS C51900 | |

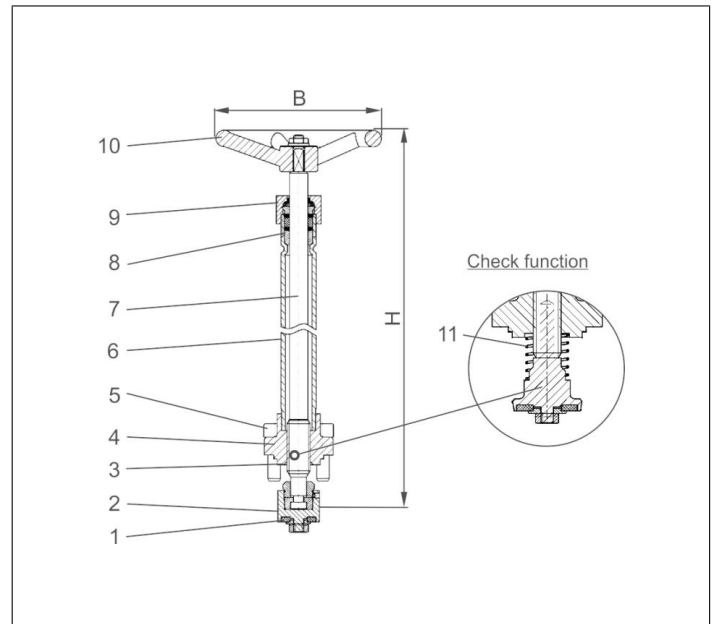

| Type 28312 | Technical data | | | | | | | in preparation | | |
|-----------------|----------------|------------------|------|------|------|------|------|----------------|-----|---|
| Nominal size | DN | 15 | 20 | 25 | 32 | 40 | 50 | 80 | 100 | |
| Dimension code | .X. | 0150 | 0200 | 0250 | 0320 | 0400 | 0500 | - | - | |
| Height | H | 270 mm or 370 mm | | | | | | | - | - |
| Number of bolts | | 4 | 4 | 4 | 4 | 4 | 6 | - | - | |
| Handwheel-Ø | B | 100 | 100 | 100 | 125 | 125 | 125 | - | - | |
| Weight | ca. kg | 1.1 | 1.4 | 1.4 | 2.0 | 2.4 | 3.0 | - | - | |

Dimensions in mm.