

Spare Parts for Valves and Fill Cluster

Type 28352 - Topwork Angle Type



for Cryogenic-Globe Valves Angle Type

Stainless steel topwork,
 "live loaded" gland packing
 "cleaned and degreased for oxygen service"

Part No. 28352.X.0000

suitable for:

| Type | Nominal size |
|-------|--------------|
| 01352 | DN15 - DN50 |

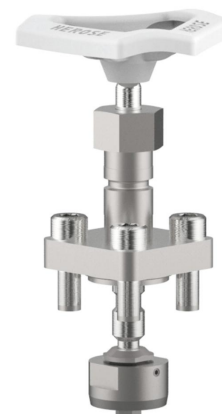

| Materials | DIN EN | ASTM |
|-----------------|----------------------------|-----------------------------|
| 1 Valve seal | PTFE / Carbon filled (25%) | |
| 2 Disc | 1.4301 | A 276 Grade 304 |
| 3 Bonnet gasket | PTFE | |
| 4 Headpiece | 1.4301 / 1.4308 | A 276 Grade 304 / A 351 CF8 |
| 5 Bolts | 1.4301/A2 | A 194 B8 |
| 6 Stem | 1.4301 | A 276 Grade 304 |
| 7 Gland packing | Graphite / PTFE | |
| 8 Gland nut | 1.4305 | A 276 Grade 303 |
| 9 Handwheel | Aluminium alloy | |
| 10 Bush | CW452K | B 159 UNS C51900 |

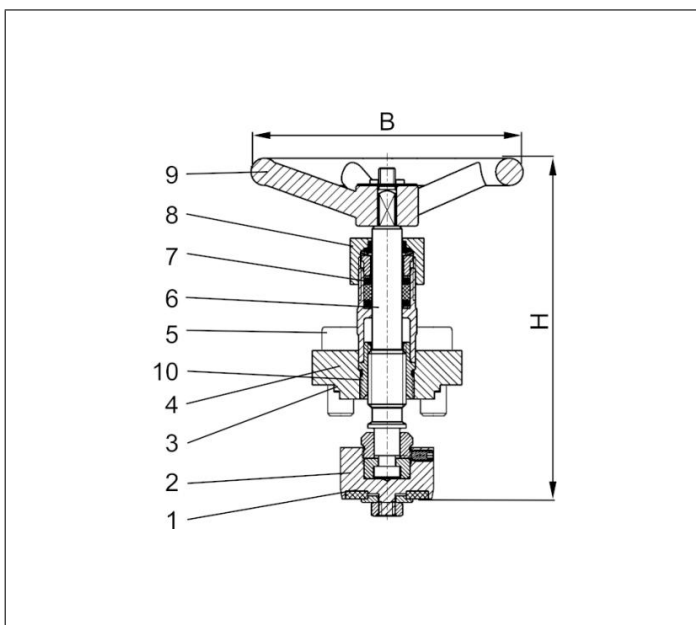

| Type 28352 | Technical data | | | | | | | in preparation | |
|-----------------|----------------|------|------|------|------|------|------|----------------|-----|
| Nominal size | DN | 15 | 20 | 25 | 32 | 40 | 50 | 80 | 100 |
| Dimension code | .X. | 0150 | 0200 | 0250 | 0320 | 0400 | 0500 | - | - |
| Height | H | 130 | 130 | 130 | 155 | 160 | 185 | - | - |
| Number of bolts | | 4 | 4 | 4 | 4 | 4 | 6 | - | - |
| Handwheel-Ø | B | 100 | 100 | 100 | 125 | 125 | 125 | - | - |
| Weight | ca. kg | 0.7 | 0.95 | 1.0 | 1.5 | 1.9 | 2.7 | - | - |

Dimensions in mm.