

Spare Parts for Fire Safe and Offshore Applications

Type 28851 - Topwork



for Cryogenic-Globe and Globe/Check Valves
 "Fire safe" type test approval acc. to EN ISO 10497

Stainless steel topwork,
 "live loaded" gland packing
 "cleaned and degreased for oxygen service"

Part No. 28851.X.0000

Part No. 28851.X.5000 with check function

suitable for:

Type	Nominal size
01851	DN10 - DN100
01855	DN10 - DN50
03851	DN25 - DN150



Materials	DIN EN	ASTM
1 Valve seal	PTFE / Carbon filled (25%)	
2 Disc	1.4401	A 276 Grade 316
3 Bonnet gasket	Graphite	
4 Headpiece	1.4404	A 276 Grade 316L
5 Bolts	1.4571/A4	similar A 194 B8T
6 Stem	1.4401	A 276 Grade 316
7 Gland packing	Graphite / PTFE / MICA	
8 Gland nut	1.4404	A 276 Grade 316L
9 Handwheel	1.4409	A 351 CF3M
10 Spring	1.4571	A 313 Grade 316Ti
11 Bush	CW452K	B 159 UNS C51900

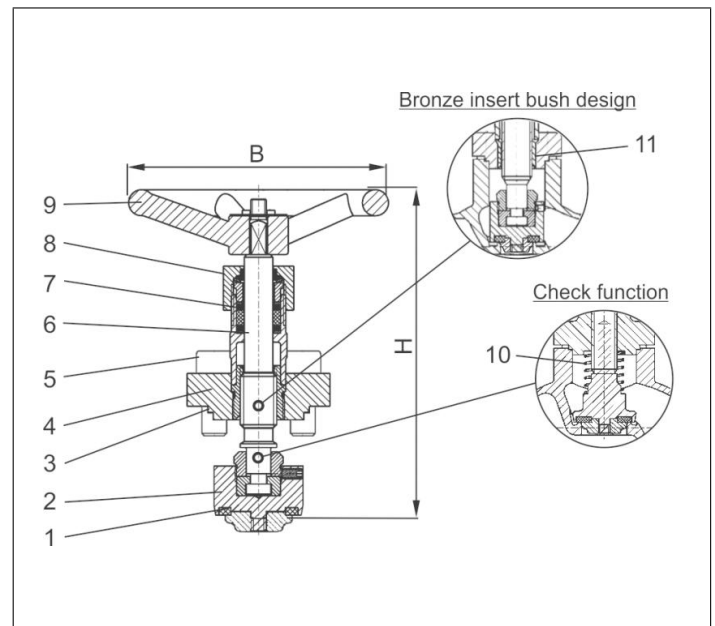

Type 28851	Technical data											
Nominal size	DN	10	15	20	25	32	40	50	65	80	100	150
Dimension code	.X.	0100	0150	0200	0250	0320	0400	0500	0650	0800	1000	1500
Height	H	130	130	130	130	155	160	185	240	285	320	380
Number of bolts		4	4	4	4	4	4	6	6	6	6	12
Handwheel-Ø	B	100	100	100	100	125	125	125	200	250	315	360
Weight	ca. kg	0.6	0.7	0.95	1.0	1.5	1.9	2.7	4.8	5.9	8.4	18.0

Dimensions in mm.