

Globe Valves

Type 03021



Globe Valves, PN16

Bronze body, screwed topwork in brass

Part No. 03021.X.0160

Part No. 03021.X.5160 Globe/Check Valve

Flanged connection acc. to DIN EN 1092-3 PN16

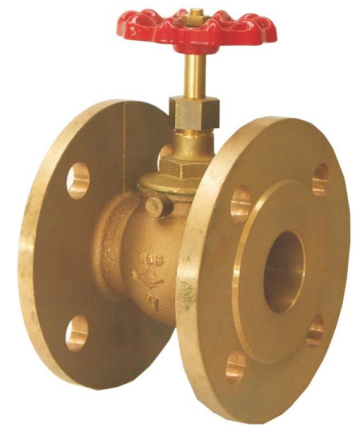

Applications:

Suitable for non-toxic, non-inflammable fluids, gases and vapours.

The laws, regulations and standards are to observe for the range of application.

Working temperatures and pressures:

up to max. 16.0 bar: -10°C / +14°F (263K) up to +80°C / +176°F (353K)

up to max. 10.0 bar: -10°C / +14°F (263K) up to +120°C / +248°F (393K)

up to max. 6.0 bar: -10°C / +14°F (263K) up to +160°C / +320°F (433K)

Materials	DIN EN	ASTM
1 Body	CC491K	B 62 UNS C83600
2 Valve seal	PTFE	
3 Disc	CW614N	B 283 UNS C38500
4 Headpiece	CW614N	B 283 UNS C38500
5 Stem	CW614N	B 283 UNS C38500
6 Handwheel	Aluminium - diecasting	
7 Spring	1.4310	A 313 Grade 301

Essential: When ordering or requesting an offer please indicate flow medium, working pressure and working temperature.

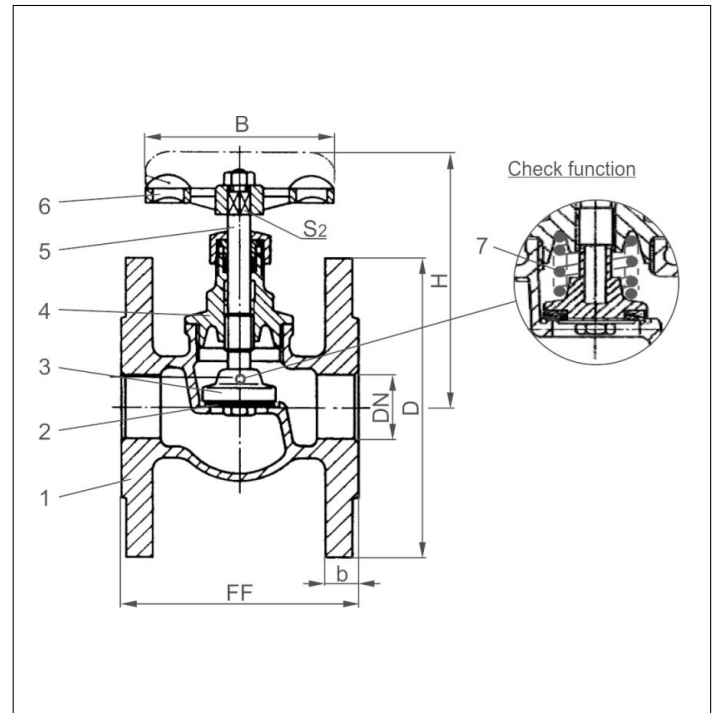

Type 03021	Technical data					
Nominal size	DN	20	25	32	40	50
Dimension code	.X.	0200	0250	0320	0400	0500
Face-to-face dimension	FF	80	90	95	110	125
Height	H	95	105	120	130	145
Flange diameter	D	105	115	140	150	165
Width of flange	b	12	12	14	14	16
Handwheel-Ø	B	60	70	80	90	110
Wrench size across flats	S ₂	6	7	8	9	9
Weight	ca. kg	1.9	2.5	3.8	4.4	6.5

Dimensions in mm.