

Globe Valves

Type 03090



Globe Valves, PN40, DIN 3356-1

Body and topwork in cast steel
seat and disc in stainless steel, metal to metal seated

Part No. 03090.X.0000

Flanged connection acc. to DIN EN 1092-1 PN40
face-to-face dimension acc. to DIN EN 558-1, Reihe 1

Available options - on request only:

- Angled Valves
- Valve with control disc

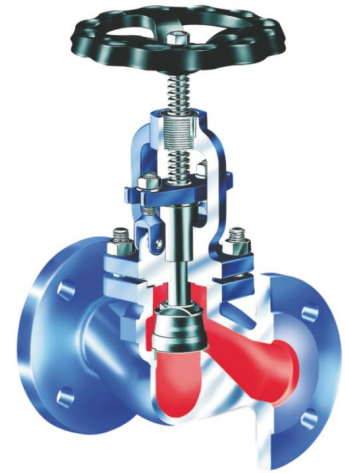

Applications:

Suitable for non-toxic, non-inflammable fluids, gases and vapours.
The laws, regulations and standards are to observe for the range of application.
Working temperatures: -10°C / +14°F (263K) up to +400°C / +752°F (673K)

Materials	DIN EN	ASTM
1 Body	1.0619	A 216 Grade WCB
2 Disc	1.4021	A 276 grade 420
3 Headpiece	1.0619	A 216 Grade WCB
4 Stem	1.4021	A 276 grade 420
5 Handwheel	cast iron	

Essential: When ordering or requesting an offer please indicate flow medium, working pressure and working temperature.

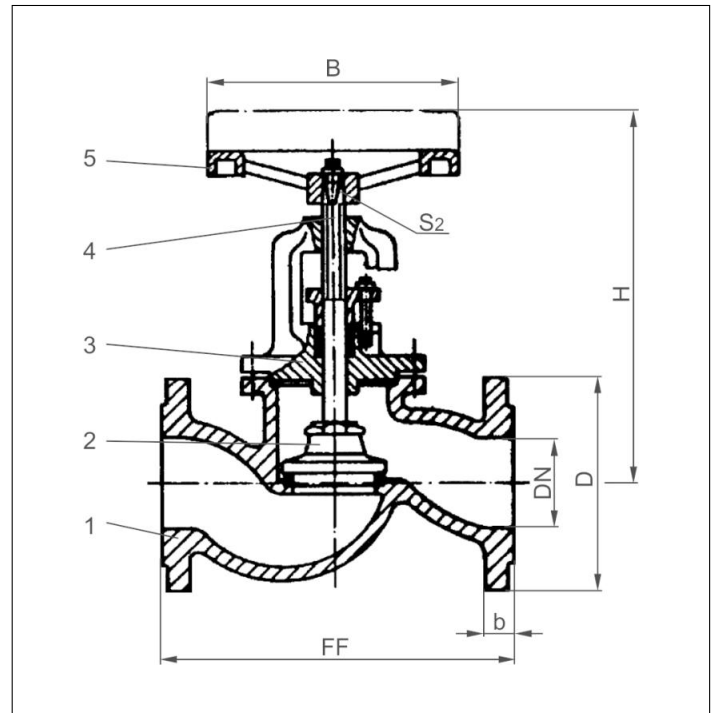

Type 03090	Technical data											
Nominal size	DN	15	20	25	32	40	50	65	80	100	125	150
Dimension code	.X.	0150	0200	0250	0320	0400	0500	0650	0800	1000	1250	1500
Face-to-face dimension	FF	130	150	160	180	200	230	290	310	350	400	480
Height	H	190	190	205	205	245	255	295	325	380	425	520
Flange diameter	D	95	105	115	140	150	165	185	200	235	270	300
Width of flange	b	12	12	12	14	14	16	16	18	20	20	22
Handwheel-Ø	B	120	120	140	140	160	160	180	200	225	250	300
Wrench size across flats	S ₂	10	10	12	12	13	13	14	15	17	18	21
Weight	ca. kg	4.4	5.4	6.3	7.0	10.5	13.8	21.0	27.5	40.0	61.0	88.5

Dimensions in mm.