

# Pressure reducing Valves

## Type 08012



### Pressure Reducing Valves

Bronze body, with balanced seat,  
disc with NBR seal, pressure gauge connection G1/4,  
inlet pressure: up to max. 25.0 bar  
outlet pressure: 0.2 up to 2.0 bar  
greatest reducing ratio: 20 : 1

### Part No. 08012.X.0000

Female thread connection (R) acc. to ISO 7-1 Rp

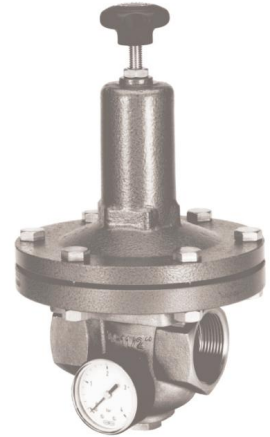

### Applications:

Suitable for compressed air, nitrogen and similar non-inflammable, non-toxic gases.  
Working temperature: -10°C / +14°F (263K) up to +75°C / +167°F (348K)

Picture:

Accessory pressure gauge - not included with valve

Materials	DIN EN	ASTM
1 Body	CC491K	B 62 UNS C83600
2 Bonnet (GW 1/4 - 1)	CW614N	B 249 UNS C38500
2 Bonnet (GW 1-1/4 - 2)	CC491K	B 62 UNS C83600
3 Spring	1.1200	A 227

**Essential:** When ordering or requesting an offer please indicate flow medium, working pressure and working temperature.

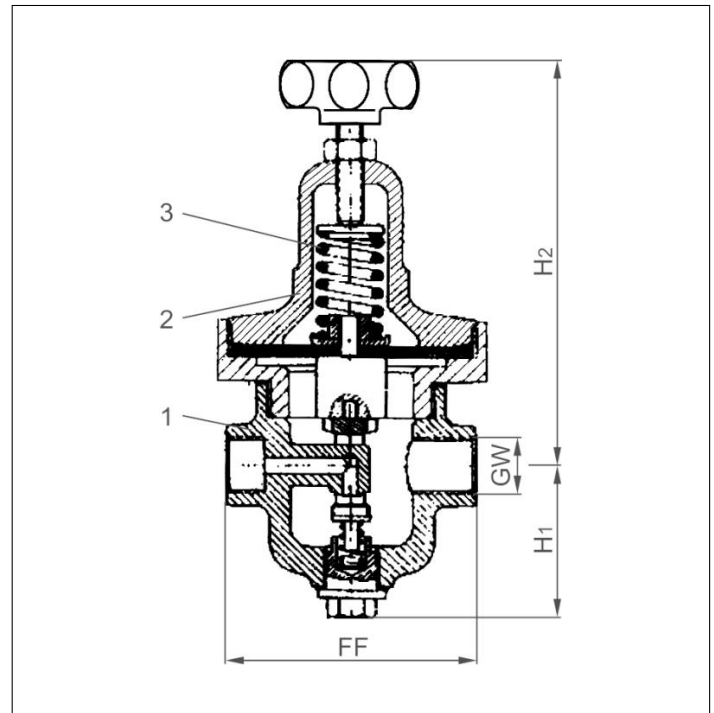

Type 08012	Technical data									
Nominal size	GW	1/4	3/8	1/2	3/4	1	1-1/4	1-1/2	2	
Dimension code	.X.	0200	0300	0400	0600	1000	1200	1400	2000	
Face-to-face dimension	FF	70	70	85	85	95	104	108	147	
Height	H <sub>1</sub>	47	47	47	47	55	60	60	66	
Height	H <sub>2</sub>	155	155	220	220	250	300	300	300	
Weight	ca. kg	1.0	1.0	2.65	2.65	4.2	7.75	12.0	13.1	

Dimensions in mm.