

Gate Valves

Type 09012



Gate Valves, PN16, DIN EN 12288

Bronze body, screwed topwork in brass with maintenance-free gland packing (O-Ring) and non rising stem

Part No. 09012.X.0000V

Female thread connection (R) acc. to ISO 7-1 Rp



Applications:

Suitable for non-toxic, non-inflammable fluids, gases and vapours. The laws, regulations and standards are to observe for the range of application.

Working temperatures and pressures:

up to max. 16.0 bar: -10°C / +14°F (263K) up to +80°C / +176°F (353K)

up to max. 10.0 bar: -10°C / +14°F (263K) up to +120°C / +248°F (393K)

up to max. 6.0 bar: -10°C / +14°F (263K) up to +180°C / +356°F (453K)

| Materials | DIN EN | ASTM |
|-------------|------------------------|------------------|
| 1 Body | CC491K | B 62 UNS C83600 |
| 2 Wedge | CC491K | B 62 UNS C83600 |
| 3 Stem | CW614N | B 283 UNS C38500 |
| 4 Headpiece | CW614N | B 283 UNS C38500 |
| 5 Handwheel | Aluminium - diecasting | |

Essential: When ordering or requesting an offer please indicate flow medium, working pressure and working temperature.

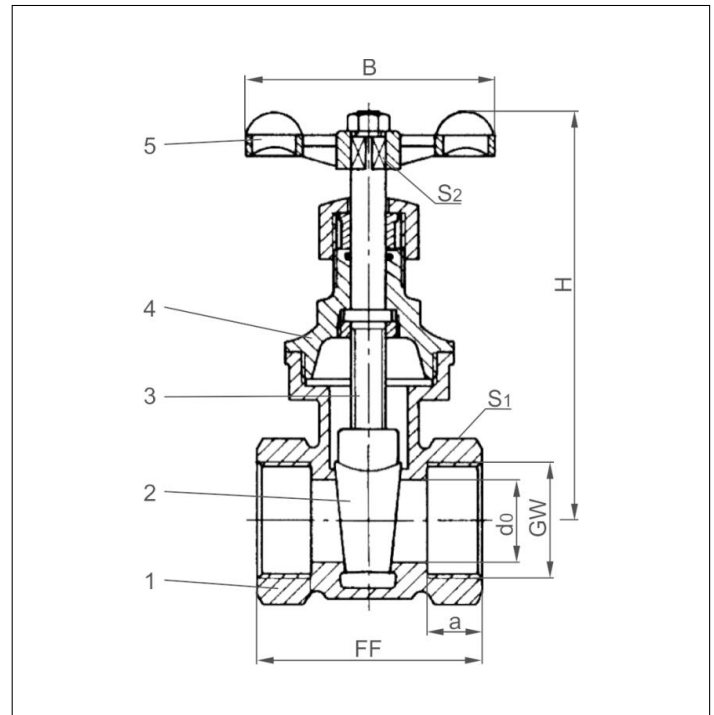

| Type 09012 | Technical data | | | | | | |
|--------------------------|----------------|------|------|------|-------|-------|------|
| Nominal size | GW | 1/2 | 3/4 | 1 | 1-1/4 | 1-1/2 | 2 |
| Dimension code | .X. | 0400 | 0600 | 1000 | 1200 | 1400 | 2000 |
| Face-to-face dimension | FF | 55 | 60 | 68 | 76 | 80 | 93 |
| Height | H | 85 | 105 | 115 | 130 | 150 | 180 |
| Socket depth | a | 15.0 | 16.3 | 19.1 | 21.4 | 21.4 | 25.7 |
| Flow diameter | d ₀ | 12.0 | 17.5 | 23.2 | 29.0 | 36.0 | 47.0 |
| Handwheel-Ø | B | 60 | 70 | 70 | 80 | 90 | 110 |
| Wrench size across flats | S ₁ | 27 | 32 | 41 | 50 | 58 | 70 |
| Wrench size across flats | S ₂ | 6 | 7 | 8 | 9 | 9 | 11 |
| Weight | ca. kg | 0.36 | 0.54 | 0.82 | 1.10 | 1.60 | 2.40 |

Dimensions in mm.