

Gate Valves

Type 09420



Flanged Gate Valves, PN16, DIN EN 12288

Bronze body, screwed topwork in brass
with maintenance-free gland packing (O-Ring)
and non rising stem
flanged connection acc. to DIN EN 1092-3 PN16

Part No. 09420.X.000000

· Standard valve

Part No. 09420.X.010000

· Valve with locking device without lock

Part No. 09420.X.020000

· Valve with locking device with lock

option:
Locking device →



Applications:

Suitable for non-toxic, non-inflammable fluids, gases and vapours.

The laws, regulations and standards are to observe for the range of application.

Working temperatures: -25°C / -13°F (248K) up to +120°C / +248°F (393K) and maximal 6.0 bar

Materials	DIN EN	ASTM
1 Body	CC491K	B 62 UNS C83600
2 Wedge	CC491K	B 62 UNS C83600
3 Stem	CW614N	B 249 UNS C38500
4 Bonnet gasket	Klingsil C-4400	
5 Headpiece	CW614N	B 249 UNS C38500
6 O-Rings	FPM (Viton)	
7 Handwheel	Aluminium - diecasting	

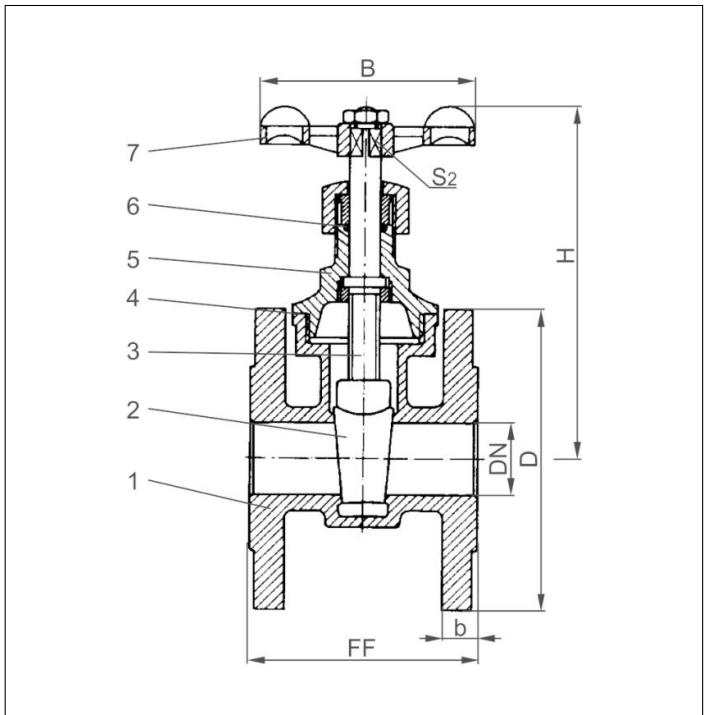

Essential: When ordering or requesting an offer please indicate flow medium, working pressure and working temperature.



Type 09420	Technical data							
Nominal size	DN	25	32	40	50	65	80	100
Dimension code	.X.	0250	0320	0400	0500	0650	0800	1000
Face-to-face dimension	FF	80	90	100	110	130	150	165
Height	H	120	130	150	180	225	250	300
Flange diameter	D	115	140	150	165	185	200	220
Width of flange	b	12	14	14	16	16	18	20
Handwheel-Ø	B	70	80	80	110	150	150	150
Wrench size across flats	S ₂	8	9	9	11	12	14	14
Weight	ca. kg	2.6	3.6	4.4	6.5	9.2	12.1	15.8

Dimensions in mm.